

## G: Gear type pump range

### G: X Style:



Materials: All materials

## Customised pumps

Our experience of designing and manufacturing bespoke high quality, purpose built pumps to satisfy operational, mounting and size/shape requirements is one of our strengths.

Albany is a leading manufacturer of standard and special purpose pumps for a very wide range of liquids. By means of the companies that have been incorporated into the Albany, over 500 years of experience in pumping technology is at the service of our customers.

We manufacture a very flexible range of pumps, which we constantly customise to meet the requirements of our users by producing bespoke product. We change seal types, mountings, connections and flanges to make the pump as convenient as possible. We also specify motors to the operating environment of our users, and to other criteria specified, such as voltage, environment and brand. Sometimes users specify other types of prime mover to be used to power their pumps, such as diesel engines.

For our OEM applications, completely custom design may be possible. We have a complete design service using the latest Solid Modelling software. The tailoring of OEM products can include special castings and mountings, special materials and additional components such as mounting plates, pipework and valves to allow products to be supplied which are ready to be fitted on arrival. Special finishes are also available from either our in-house painting facility or where necessary by sub contracting.

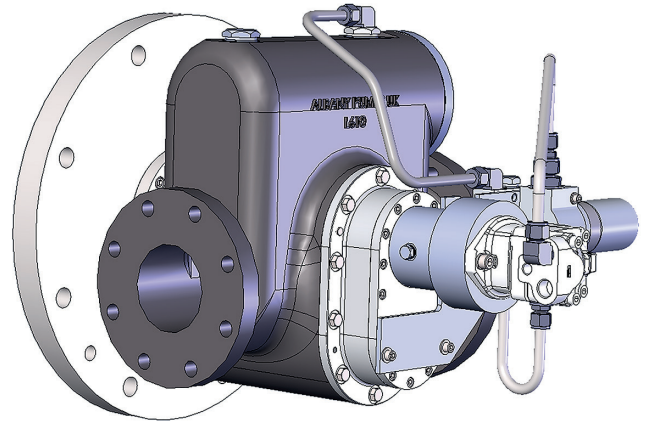

Albany's 24-page brochure is available as a download at [www.albany-pumps.co.uk](http://www.albany-pumps.co.uk)



Maximum working pressure <b>40 barg</b>	Pump size range <b>1/2" - 6"</b>	Maximum temperature <b>220°C</b>	Flow rate <b>25-1900 L/min</b>
---	----------------------------------	----------------------------------	--------------------------------

AL Aluminium | CS Cast Steel | CI Cast Iron | GM Gunmetal | HY Hastelloy | NR Ni-resist | NY Nylon | PP Polypropylene | SD Super Duplex | SS Stainless Steel  
 General and Chemical | Bitumen | Fire | Dispenser Machines | Food Industry | Lubrication | Marine | Oil & Gas | Refrigeration | Sugar

[www.albany-pumps.co.uk](http://www.albany-pumps.co.uk) +44 (0) 1594 842 275

### Head Office and Manufacturing Centre

Albany Engineering Company Ltd  
 Church Road, Lydney  
 Gloucestershire, GL15 5EQ  
 United Kingdom

t: +44 (0) 1594 842 275  
 Head Office Option 1

e: [salesdept@albany-pumps.co.uk](mailto:salesdept@albany-pumps.co.uk)

### Service and Repair Centre

Albany Engineering Company Ltd  
 Richter Works, Garnett Street  
 Bradford BD3 9HB  
 United Kingdom

t: +44 (0) 1594 842 275  
 Service and Repair (Option 2).

e: [servicedept@albany-pumps.co.uk](mailto:servicedept@albany-pumps.co.uk)